

442

Zero Tail Swing

Excavator



One Tough Animal™

THE LARGEST EXCAVATOR IN THE BOBCAT LINEUP!

Work With It!

Bobcat Model 442 Excavator

Here's plenty of power for bigger jobs — excavation, demolition, construction, material handling and placement. The new Bobcat® 442 delivers the strength you need on any jobsite.



Comfortable Cab

The fully-enclosed cab offers all-around visibility, adjustable arm-rests and suspension seat. Heater and air conditioner are standard.



Multi-Position Front Window

The window can be completely closed during inclement weather, partially open for ventilation, or fully open to keep the operator comfortable in any season.

Lifting Capacity

Contributing to the 442's performance is the excavator's rated lift capacity — an impressive 3,395 pounds at maximum reach. With the Bobcat 442, you'll dig deeper, work faster and lift more!

Zero Tail Swing

No tail swing means increased productivity because spoil placement is easier. There's also less chance to damage the excavator or surrounding objects, reducing the costs of maintenance and jobsite damage repair — while enhancing the resale value of the machine.



Digging Force

Check out the 442's hefty digging force, combining arm breakout of 9,585 lbf. and bucket breakout of 11,970 lbf.





Self-Cleaning Undercarriage

The durable H-frame undercarriage features sloping edges that shed material and minimize accumulation of mud and debris.

Piston Pump Hydraulic System

An axial piston pump driven by the engine flywheel delivers maximum hydraulic horsepower for the working equipment — boom, dipper, bucket, auxiliary hydraulics and travel functions. The system also permits smooth, precise control of functions under a wide range of loads and speeds. Additionally, a tandem gear pump system provides flow for the blade, boom offset and slew functions.



Serviceability

Two flip-up hoods provide easy access to service points, making daily maintenance simple and convenient. The battery is maintenance-free.



Top-Mounted Boom Cylinder

The boom cylinder is mounted above the boom structure for protection against damage from impact while excavating.

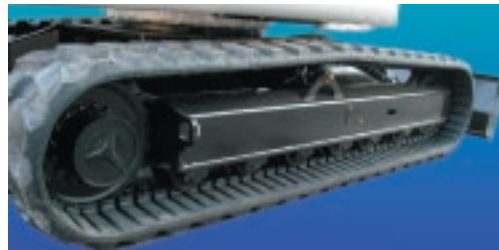

Staggered/Alternating Track Rollers

The configuration of the track rollers spreads the contact area between track and roller over more surface area, extending component life and reducing the chance of de-tracking.

Instrumentation

Conveniently located on the operator's right side, the instrument panel monitors the 442's vital signs:

- Hour meter
- Fuel level
- Coolant temperature
- Charging system
- Pre-heating monitor
- Engine oil pressure
- Air filter restriction indicator
- Hydraulic filter restriction indicator
- Hydraulic oil level

ISO/STD Valve

By simply pressing a switch on the dash panel, the operator can instantly choose between ISO or Standard control patterns.

Control Console Lockout

Raising the left console locks out the work group, travel and auxiliary hydraulic functions.



Backfill Blade

The standard-equipped 92-inch dozer blade is unbeatable for backfilling, dozing and hauling. It also serves as a stabilizer, increasing digging performance and lifting capacity. The 442's blade float feature enhances grading, leveling and scraping chores.



442

EXCAVATOR

Worldwide Support.

With the Bobcat 442, you get more than an exceptional excavator. You also get the support of a worldwide network of Bobcat dealers offering industry-leading attachments, accessories and parts availability. Their factory-trained service technicians are equipped to handle all your parts and service requirements, including engine and hydrostatic/hydraulic components. There's an excellent warranty program, too. Get all the details from your Bobcat dealer.

Specifications

Performance

442

Operating Weight (rubber)	16,538 lb. (7500 kg)
Travel Speed	
Low	1.7 mpg (2.7 km/h)
High	3.2 mph (5.2 km/h)
Hydraulic Pumps	3
Type	Piston/Gear
Total Capacity	59.1 gpm (224 L/m)
Auxiliary Flow	26.4 gpm (100 L/m)
Hydraulic System Capacity	37 gal. (140 L)
Fuel Tank Capacity	34 gal. (130 L)
Track Shoes	Rubber/Steel
Width	18 in. (45 mm)
Ground Pressure	4.4 psi (30.34 kPa)
Overall Width	92 in. (2337 mm)

Working Range

Arm Length	79 in. (2000 mm)
Max. Digging Height	20 ft., 3 in. (6170 mm)
Max. Dumping Height	13 ft., 8 in. (4160 mm)
Max. Digging Depth	13 ft., 11 in. (4250 mm)
Max. Vertical Wall Digging Depth	8 ft., 8 in. (2630 mm)
Max. Reach	23 ft., 10 in. (7260 mm)
Arm Breakout Force	9,585 lbf. (42600 N)
Bucket Breakout Force	11,970 lbf. (53200 N)

Engine

Make/Model	Deutz/KHD-BF-4M-2011E
Fuel	Diesel - Turbo
Cooling	Oil Cooled
Displacement	195 cu. in. (3.21 L)
Horsepower	73 hp (54 kw) @ 2200 rpm

Rated Lift Capacity

Rated Lift Capacity Over End, Blade Down, Maximum Radius, Ground Level	3,395 lb. (1540 kg)
---	---------------------

Drive/Swing System

Swing Speed	10 rpm
Swing Clearance, Rear	0 in. (0 mm)
Boom Swing	
Left	63°
Right	65°

Standard Features

7' 8" Dozer Blade	Electrical Disconnect
18" Tracks (Rubber or Steel)	Horn
2-Speed Travel	Hydraulic Joystick Controls
Blade Float	Seat Belt
Boom Anti-Drop Valve	Spark Arrester Exhaust System
Enclosed Cab with Heater and Air Conditioning	Suspension Seat, with High Back
Control Console Locks	Work Light (cab mounted)
Control Pattern Selector Valve (ISO/STD)	

Accessories

AM/FM Radio Kit	Security Ignition Kit
Floodlight Kit	Travel Motion Alarm Kit

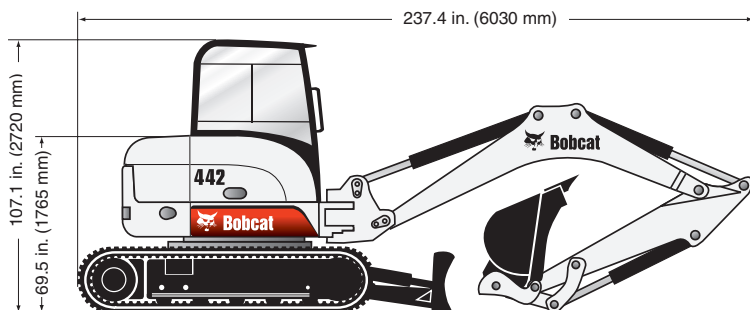

442 EXCAVATOR — THE BIG ONE FROM BOBCAT COMPANY!

Sure, the job is tough — but the 442 is tougher. This is one big bruiser of an excavator, ready to take on the hardest, heaviest work you've got.

What kind of hard work? Excavation. Construction. Demolition. Material handling and placement. The Bobcat® 442 is the ideal machine for contractors, landscapers, utilities and rental operators. It's everything you demand in an excavator — and much, much more.

Digging Force

When it comes to strength, the 442 boasts exceptional digging force, combining arm breakout of 9,585 lbf. and bucket breakout of 11,970 lbf.

Lifting Capacity

Here's more strength — a whopping 3,395-pound rated lift capacity at maximum reach. With the Bobcat 442, you'll dig deeper, work faster and lift more!

Zero Tail Swing

This feature assures easier spoil placement, increased productivity, and less chance of damage to the excavator or surrounding objects.

Work With It!

To sum up — the Bobcat 442 excavator is a big, rugged, dependable machine that digs into the toughest jobs, chews 'em, up, and spits 'em out!

Working Range

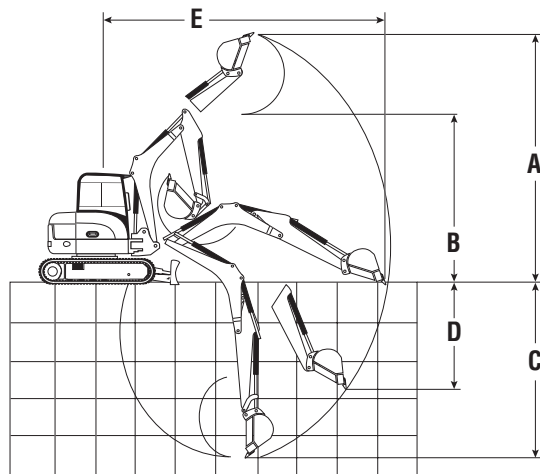

442

A. Max. Digging Height	243 in. (6170 mm)
B. Max. Dumping Height	164 in. (4160 mm)
C. Max. Digging Depth	167 in. (4250 mm)
D. Max. Vertical Wall Digging Depth	104 in. (2630 mm)
E. Max. Digging Reach	286 in. (7260 mm)
Arm Length	79 in. (2000 mm)
Bucket Breakout Force	11,970 lbf. (53,200 N)

NOTE — Where applicable, dimensions are in accordance with Society of Automotive Engineers (SAE) and ISO standards. Specifications and design are subject to change without notice. Pictures of Bobcat excavators may show other than standard equipment. All dimensions are shown in inches. Respective metric dimensions are enclosed by parentheses. Bobcat Company complies with the requirements of ISO 9001 as registered with BSI.

The Bobcat Attachments Advantage: Bobcat attachments are engineered and manufactured to fit Bobcat excavators for optimum job performance, dependability and durability.

Bobcat Attachments for this model:

- Ejector Bucket
- Grading Bucket
- Hydraulic Breaker
- Hydraulic Clamp
- Plate Compactor
- Ripper
- Rotating
- Clamshell Bucket
- Tilt Bucket
- Trenching Bucket

